

HAFCO METALMASTER



Edition : 1.0
Date: (05/24)

Instruction Manual

MILL DRILL MACHINE HM-48B

Order Code: (K8742D)

MACHINE DETAILS

MACHINE	Mill Drill Machine
MODEL NO.	HM-48B
SERIAL NO.	
DATE OF MANF.	

Imported by

Australia

New Zealand



www.machineryhouse.com.au

www.machineryhouse.co.nz

NOTE:

This manual is only for your reference. At the time of the compiling of this manual every effort to be exact with the instructions, specifications, drawings, and photographs of the machine was taken. Owing to the continuous improvement of the HAFCO METALMASTER machine, changes may be made at any time without obligation or notice. Please ensure the local voltage is the same as listed on the specification plate before operating any electric machine.

SAFETY SYMBOLS:

The purpose of safety symbols is to attract your attention to possible hazardous conditions



Indicates a potentially hazardous situation causing injury or death



Indicates an alert against unsafe practices.

Note: Used to alert the user to useful information



Fig.1

NOTE:

In order to see the type and model of the machine, please see the specification plate. Usually found on the back of the machine. See example (Fig.1)

HAFCO METALMASTER	
PRODUCT SPECIFICATIONS	
Model: HM-48B	Voltage: 240V/50Hz
Capacity: 820 x 240	Motor: 1.5kW
Nett Weight: 430kg	FLC: 7.1A
MFG Date:	
Serial No:	<input type="text"/>
Imported by www.machineryhouse.com.au	Made in China www.machineryhouse.co.nz

CONTENTS:

1. GENERAL MACHINE INFORMATION	
1.1 Specifications.....	4
1.2 Identification.....	5
1.3 Electrical Controls.....	6
1.4 Accessories.....	7
2. SAFETY	
2.1 General Metalworking Machine Safety.....	8
2.2 Safe Working Area Diagram.....	10
2.3 Specific Safety For Drill/Mill.....	11
3. POWER SUPPLY	
3.1 Electrical Installation.....	12
3.2 Full Load Current.....	12
4. SETUP	
4.1 Unpacking.....	13
4.2 Clean Up.....	13
4.3 Site Preparation.....	13
4.4 Lifting Instructions.....	13
4.5 Machine Levelling.....	14
4.6 Assembly.....	15
4.7 Basic Controls.....	16
4.8 Test Run.....	17
5. OPERATION	
5.1 Operation Overview.....	18
5.2 Headstock Z-Axis Movement.....	19
5.3 Tilting The Head.....	20
5.4 Down Feed Controls.....	21
5.5 Setting Up For Tapping.....	22
5.6 Table Movement.....	23
5.7 Installing & Removing The Tooling.....	24
5.8 Changing The Speeds.....	25
5.9 Digital Spindle Height Gauge.....	26
5.10 Power Feed Unit.....	26
5.11 Hafco Digital Readout.....	27
6. MAINTENANCE	
6.1 Lubrication.....	29
6.2 Changing The Gearbox Oil.....	29
6.3 Gib Adjustment.....	30
6.4 Troubleshooting.....	31
Spare Parts.....	32
Risk Assessment Sheets.....	39

1.1 SPECIFICATION

Order Code	K8742D
MODEL	HM-48B
Digital Readout	3 Axis Digital Readout
Type	Vertical
Table Size (mm)	820 x 240
Column Type	Dovetail
Spindle Taper (mt)	3
Spindle Diameter (mm)	75
Spindle Travel (mm)	120
Spindle Speeds (No / Range)	6 (95 - 1650)
Longitudinal Travel (X-Axis) (mm)	670
Cross Travel (Y-Axis) (mm)	185
Vertical Travel (Z-Axis) (mm)	410
Spindle to Table (mm)	480
Throat Depth (Max) (mm)	273
Tilting Head (Left ~ Right) (deg)	±90
Tilting Head (Forward ~ Back)	Fixed
Drilling Capacity (mm)	31.5
End Mill Capacity (mm)	28
Face Milling Capacity (mm)	75
Power Feed - Longitudinal (X-Axis)	Yes
Table T-Slot (mm)	14
Work Table Load Capacity (kg)	60
Motor Power (kW / hp)	1.5 / 2
Voltage / Amperage (v / a)	240 / 10
Dimensions (L x W x H) (mm)	1220 x 950 x 1150
Weight (kg)	430

1.3 IDENTIFICATION

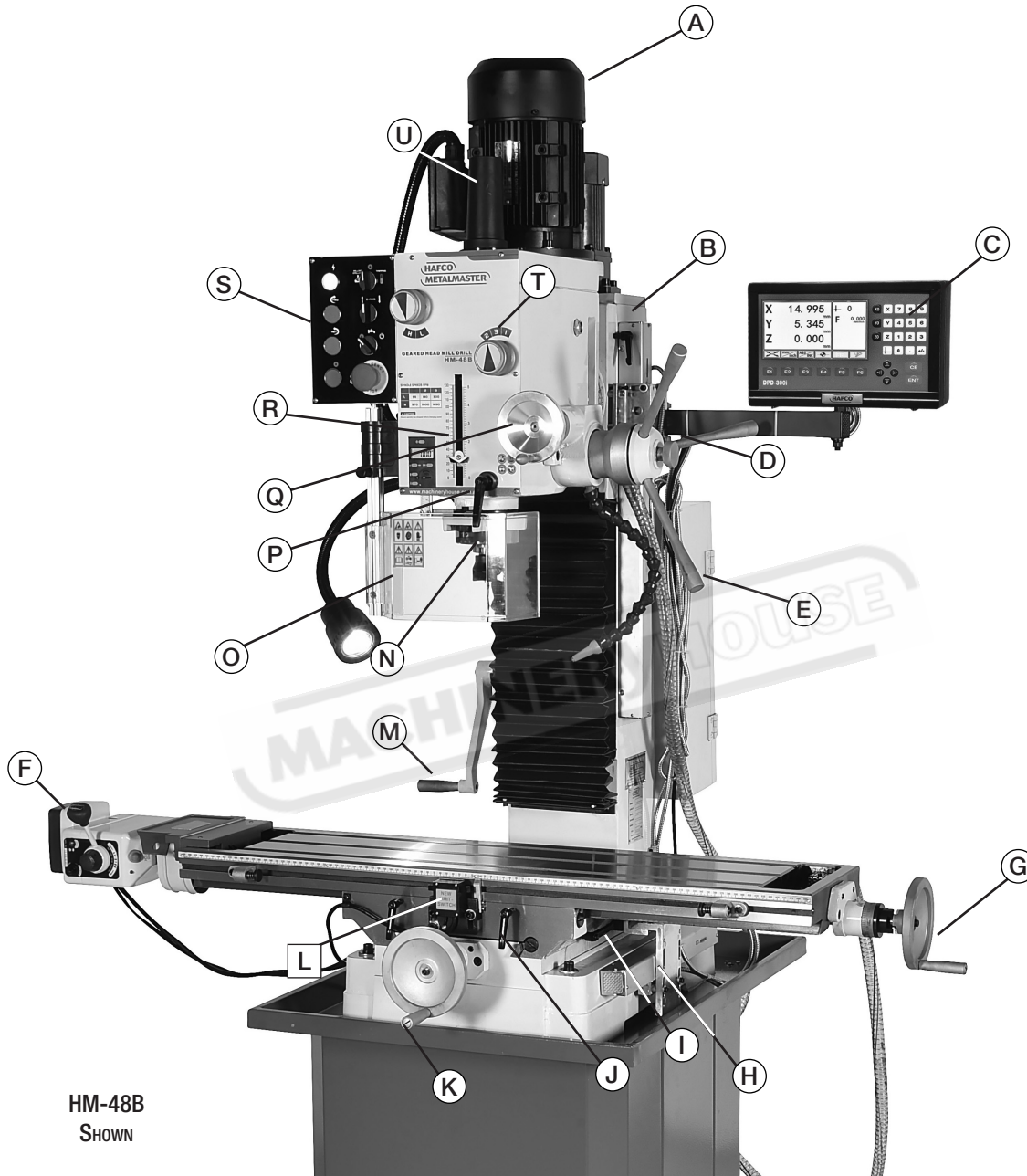

HM-48B
SHOWN

A	Motor	H	Y Axis Table Scale	O	Spindle Guard
B	Z Axis Lock	I	Y Axis Table Lock	P	Spindle Lock
C	Digital Readout	J	X Axis Table Lock	Q	Fine Down-feed Handle
D	Down-feed Selector Knob	K	Y Axis Handle	R	Depth Stop Scale
E	Course Down-feed Handle	L	Table Travel Stop	S	Control Panel
F	Power Feed	M	Vertical Handle	T	Speed Selectors
G	X Axis Handles	N	Spindle	U	Drawbar Cover

1.3 ELECTRICAL CONTROLS

The descriptions below can be used to gain a basic understanding of the control panel. Knowing this information is required to safely complete the Test Run.

- A. FORWARD BUTTON:** Starts clockwise spindle rotation (as viewed from above). The spindle must be completely stopped before this button is pushed.
- B. REVERSE BUTTON:** Starts counter-clockwise spindle rotation (as viewed from above). The spindle must be completely stopped before this button is pushed.
- C. POWER LAMP:** Illuminates when the machine is connected to power.
- D. STOP BUTTON:** Stops spindle rotation.
- E. MODE TOGGLE SWITCH:** Selects either Milling and Drilling, Tapping mode or stop when the switch is in the centre position.
- F. COOLANT SWITCH:** Switches the coolant pump on or off.
- G. EMERGENCY STOP BUTTON:** Cuts power to the spindle motor and remains depressed until reset. Twist clockwise until it pops out to reset.
- H. ELEVATION SWITCH:** Rapid traverse to raise or lower the head on the Z axis.

HM-48B

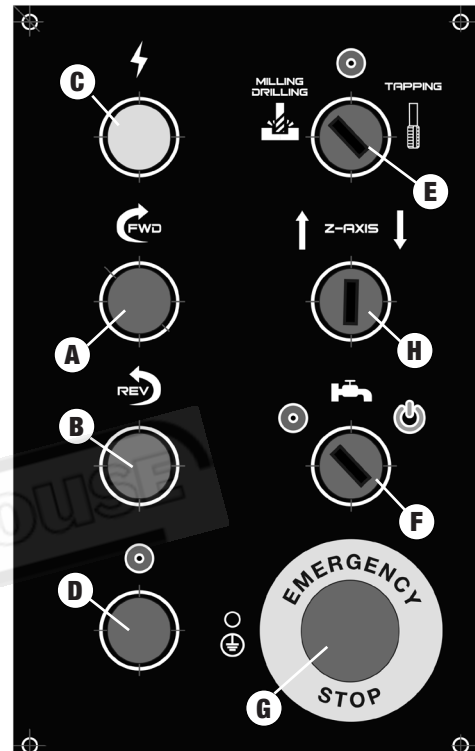

WARNING.

To avoid damaging gears, ALWAYS make sure the spindle is completely stopped BEFORE moving the spindle speed levers.

1.4 ACCESSORIES

The following is a list of items shipped with your machine. Before beginning setup, lay these items out and inventory them. If any non-proprietary parts are missing then contact your local dealer.

- | | |
|-------------------------------------|------------------------------------|
| Digital tilting head gauge | Plastic Oil Can |
| Drill chuck, arbor & Key | Hex Keys |
| Face cutter & arbor | Spanner |
| Safety cutter guard (Not displayed) | Tool Box |
| 3-2mt sleeve | Instruction Manual (Not displayed) |
| Drill Drifts | |
| M12 x 1.75mm drawbar | |
| 1/2" X 12tpi whitworth drawbar | |



2.1 GENERAL METALWORKING MACHINE SAFETY

DO NOT use this machine unless you have read this manual or have been instructed in the use of this machine in its safe use and operation



WARNING

This manual provides safety instructions on the proper setup, operation, maintenance, and service of this machine. Save this manual, refer to it often, and use it to instruct other operators. Failure to read, understand and follow the instructions in this manual may result in fire or serious personal injury—including amputation, electrocution, or death.

The owner of this machine is solely responsible for its safe use. This responsibility includes, but is not limited to proper installation in a safe environment, personnel training and authorization to use, proper inspection and maintenance, manual availability and comprehension, of the application of the safety devices, integrity, and the use of personal protective equipment.

The manufacturer will not be held liable for injury or property damage from negligence, improper training, machine modifications or misuse.



- ✓ Always wear safety glasses or goggles.
- ✓ Wear appropriate safety footwear.
- ✓ Wear respiratory protection where required.
- ✓ Gloves should never be worn while operating the machine, and only worn when handling the workpiece.
- ✓ Wear hearing protection in areas > 85 dBA. If you have trouble hearing someone speak from one metre (three feet) away, the noise level from the machine may be hazardous.
- ✓ DISCONNECT THE MACHINE FROM POWER when making adjustments or servicing.
- ✓ Check and adjust all safety devices before each job.
- ✓ Ensure that guards are in position and in good working condition before operating.
- ✓ Ensure that all stationary equipment is anchored securely to the floor.
- ✓ Ensure all machines have a start/stop button within easy reach of the operator.
- ✓ Each machine should have only one operator at a time. However, everyone should know how to stop the machine in an emergency.

2.1 GENERAL METALWORKING MACHINE SAFETY CONT.

- ✓ Ensure that keys and adjusting wrenches have been removed from the machine before turning on the power. Appropriate storage for tooling should be provided.
- ✓ Ensure that all cutting tools and blades are clean and sharp. They should be able to cut freely without being forced.
- ✓ Stop the machine before measuring, cleaning or making any adjustments.
- ✓ Wait until the machine has stopped running to clear cuttings with a vacuum, brush or rake.
- ✓ Keep hands away from the cutting head and all moving parts.
- ✓ Avoid awkward operations and hand positions. A sudden slip could cause the hand to move into the cutting tool or blade.
- ✓ Return all portable tooling to their proper storage place after use.
- ✓ Clean all tools after use.
- ✓ Keep work area clean. Floors should be level and have a non-slip surface.
- ✓ Use good lighting so that the work piece, cutting blades, and machine controls can be seen clearly. Position any shade lighting sources so that they do not cause any glare or reflections.
- ✓ Ensure there is enough room around the machine to do the job safely.
- ✓ Obtain first aid immediately for all injuries.
- ✓ Understand that the health and fire hazards can vary from material to material. Make sure all appropriate precautions are taken.
- ✓ Clean machines and the surrounding area when the operation is finished.
- ✓ Use proper lock out procedures when servicing or cleaning the machines or power tools.

DO NOT

- × Do not distract an operator. Horseplay can lead to injuries and should be strictly prohibited.
- × Do not wear loose clothing, gloves, neckties, rings, bracelets or other jewellery that can be come entangled in moving parts. Confine long hair.
- × Do not handle cuttings by hand because they are very sharp. Do not free a stalled cutter without turning the power off first. Do not clean hands with cutting fluids.
- × Do not use rags or wear gloves near moving parts of machines.
- × Do not use compressed air to blow debris from machines or to clean dirt from clothes.
- × Do not force the machine. It will do the job safer and better at the rate for which it was designed.



WARNING. Read and understand the instructions in this manual, before operating this machine to reduce the risk of serious injury or even death.

2.1 GENERAL METALWORKING MACHINE SAFETY CONT.

HAZARDS ASSOCIATED WITH MACHINES include, but are not limited to:

- Being struck by ejected parts of the machinery
- Being struck by material ejected from the machinery
- Contact or entanglement with the machinery
- Contact or entanglement with any material in motion

Health Hazards (other than physical injury caused by moving parts)

- Chemicals hazards that can irritate, burn, or pass through the skin
- Airborne items that can be inhaled, such as oil mist, metal fumes, solvents, and dust
- Heat, noise, and vibration
- Ionizing or non-ionizing radiation (X-ray, lasers, etc.)
- Biological contamination and waste
- Soft tissue injuries (for example, to the hands, arms, shoulders, back, or neck) resulting from repetitive motion, awkward posture, extended lifting, and pressure grip)

Other Hazards

- Slips and falls from and around machinery during maintenance
- Unstable equipment that is not secured against falling over
- Safe access to/from machines (access, egress)
- Fire or explosion
- Pressure injection injuries from the release of fluids and gases under high pressure
- Electrical Hazards, such as electrocution from faulty or ungrounded electrical components
- Environment in which the machine is used (in a machine shop, or in a work site)

2.2 SAFE WORKING AREA DIAGRAM

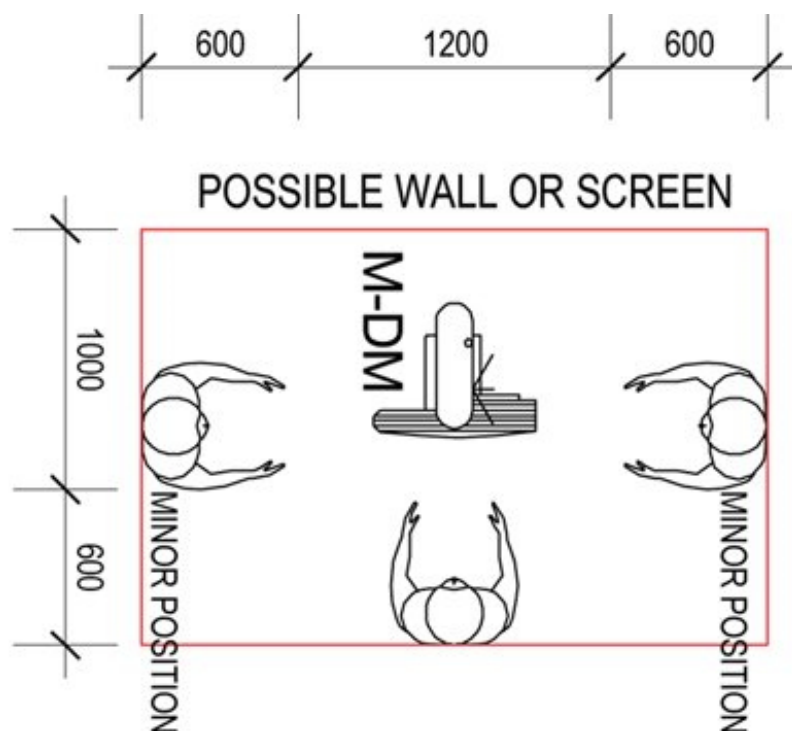

2.3 SPECIFIC SAFETY FOR DRILL/MILL

DO NOT use this machine unless you have been instructed in its safe use and operation and have read and understood this manual



Safety glasses must be worn at all times in work areas



Long and loose hair must be contained



Gloves must not be worn when operating the machine



Sturdy footwear must be worn at all times in work areas



Close fitting/protective clothing must be worn



Rings and jewellery must not be worn.

PRE-OPERATIONAL SAFETY CHECKS

- ✓ Locate and ensure you are familiar with all machine operations and controls.
- ✓ Ensure all guards are fitted, secure and functional. Do not operate if guards are missing or faulty.
- ✓ Check workspaces and walkways to ensure no slip/trip hazards are present
- ✓ Ensure cutter is in good condition and securely mounted.
- ✓ Check coolant delivery system (if used) to allow for sufficient flow of coolant.

OPERATIONAL SAFETY CHECKS

- ✓ Keep clear of moving machine parts.
- ✓ Follow correct clamping procedures. Keep overhangs as small as possible and check work piece is secure.
- ✓ Set the correct speed to suit the cutter diameter, the depth of cut and the material.
- ✓ Feed the workpiece against the milling cutter.

ENDING OPERATIONS AND CLEANING UP

- ✓ Switch off the machine when work completed.
- ✓ Remove milling cutters and store them safely.
- ✓ Before making adjustments and measurements or cleaning swarf accumulations, switch off and bring the machine to a complete standstill.
- ✓ Leave the machine and work area in a safe, clean and tidy state.

POTENTIAL HAZARDS AND INJURIES

- Sharp cutters.
- Hair/clothing getting caught in moving machine parts.
- Eye injuries.
- Metal splinters and burrs.
- Flying debris.

DON'T

- × Do not use faulty equipment. Immediately report suspect machinery.
- × Never leave the machine running unattended.
- × Do not leave equipment on top of the machine.

3. POWER SUPPLY

3.1 ELECTRICAL INSTALLATION

Place the machine near an existing power source. Make sure all power cords are protected from traffic, material handling, moisture, chemicals, or other hazards. Make sure there is access to a means of disconnecting the power source. The electrical circuit must meet the requirements for 240V.

NOTE : The use of an extension cord is not recommended as it may decrease the life of electrical components on your machine.

ELECTRICAL REQUIREMENTS

Nominal Voltage.....	240V
Cycle.....	50 Hz
Phase.....	Single Phase
Power Supply Circuit.....	10 Amps
Full Load Current.....	7.1 Amps

(Full load current rating is also on the specification plate on the motor.)

3.2 FULL-LOAD CURRENT RATING

The full-load current rating is the amperage a machine draws when running at 100% of the output power. Where machines have more than one motor, the full load current is the amperage drawn by the largest motor or a total of all the motors and electrical devices that might operate at one time during normal operations.

Full-Load Current Rating for these machine at 240V is 7.1 Amps

It should be noted that the full-load current is not the maximum amount of amps that the machine will draw. If the machine is overloaded, it will draw additional amps beyond the full-load rating and if the machine is overloaded for a long period of time, damage, overheating, or fire may be caused to the motor and circuitry.

This is especially true if connected to an undersized circuit or a long extension lead. To reduce the risk of these hazards, avoid overloading the machine during operation and make sure it is connected to a power supply circuit that meets the requirements.



4 SETUP

4.1 UNPACKING

This machine was carefully packaged for safe transport. When unpacking, separate all enclosed items from packaging materials and inspect them for shipping damage. If items are damaged, please contact your distributor.

NOTE: Save all the packaging materials until you are completely satisfied with the machine and have resolved any issues with the distributor, or the shipping agent.

When unpacking, check the packing list to make sure that all parts shown are included. If any parts are missing or broken, please contact the your distributor.

4.2 CLEAN - UP

The unpainted surfaces of the machine have been coated with a waxy oil to protect them from corrosion during shipment. Remove the protective coating with a solvent cleaner or a citrus based degreaser.

Optimum performance from your machine will be achieved when you clean all moving parts or sliding contact surfaces that are coated with rust prevented products.

It is advised to avoid chlorine based solvents, such as acetone or brake parts cleaner, as they will damage painted surfaces and strip metal should they come in contact. Always follow the manufacturer's instructions when using any type of cleaning product.

4.3 SITE PREPARATION

When selecting the site for the machine, consider the largest size of workpiece that will be processed through the machine and provide enough space around the machine for operating the machine safely. Consideration should be given to the installation of auxiliary equipment. Leave enough space around the machine to open or remove doors/covers as required for the maintenance and service as described in this manual.

It is recommended that the machine is anchored to the floor to prevent tipping or shifting. It also reduces vibration that may occur during operation.

4.4 LIFTING INSTRUCTIONS



WARNING

This machine is extremely heavy. Serious personal injury may occur if safe moving methods are not followed. To be safe, you will need assistance and power equipment when moving the shipping crate and removing the machine from the crate.



On the day that the machine arrives, make sure that a forklift or lifting device, with sufficient capacity is available to unload the machine from the vehicle. Ensure access to the chosen site is clear and that doors and ceilings are sufficiently high and wide enough to receive the machine.

LIFTING POINTS

When lifting the machine only certified lifting slings should be used. Ensure that when lifting, the machine does not tip over. Check that the lifting slings do not interfere with the hydraulic pipes or electrical conduits. Failure to follow these instructions could cause damage to the machine.

1. Move the shipping crate next to the workbench or optional stand, then unbolt machine from pallet.
2. Move table as close to column as possible, and raise head stock to its highest position. This will help balance machine when moving.
3. Tighten Z-axis locks to avoid sudden shifts when lifting.
4. Place a lifting strap under headstock, as shown in Fig. 4.1 connect strap ends to a forklift or hook, then lift and place machine on the workbench or on the optional stand.



FIG. 4.1

MOUNTING METHODS

If the machine is mounted on the optional stand, it should be bolted to the floor or concrete slab (Fig. 4.3)

Masonry anchors with bolts are the best way to anchor machinery, because the anchors sit flush with the floor surface, making it easy to unbolt and move the machine later, if needed. (Fig. 4.2)



FIG. 4.2

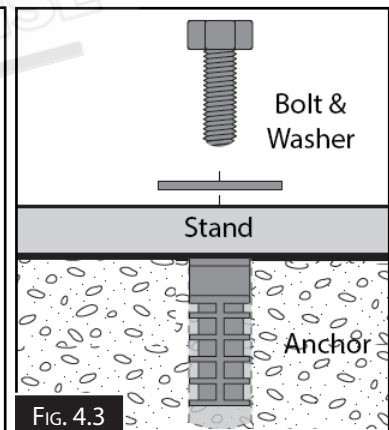

FIG. 4.3

4.5 MACHINE LEVELLING

To set your machine up so that it operates to optimum performance, the machine should be level. To level the machine follow the procedure below.

After your machine base has been anchored to a concrete slab floor, then the levelling is performed by loosening the hold down bolts, and then inserting metal shims under each hold down bolt until the machine is level and does not rock. (Fig. 4.4). Place a level on the surface of the working table to check if level. The tolerance should be 1000:0.30mm, for both longitudinal and transverse.

Once the machine is level, then tighten the hold down bolts.

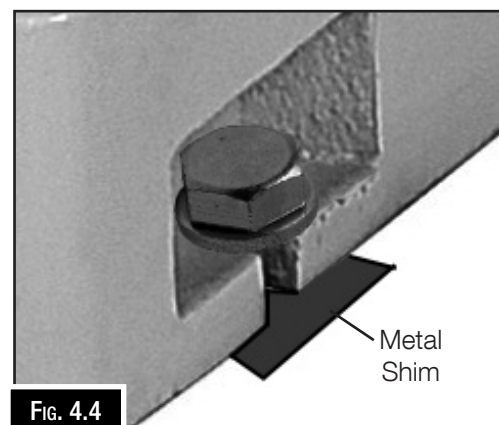

FIG. 4.4

4.6 ASSEMBLY

Before the machine can be installed the stand must be assembled. Lay out all the pieces below on a clean area and put the stand together. (Fig. 4.5)

To assemble the stand

1. Attach the connecting plates (2) to the side plates (3 and 4) with the 10 off M8 x 16 socket head screws (12), 2 x M8 washers(13) and M8 nuts (14). Leave all the nuts and bolts loose until the stand is completely assembled the tighten all the bolts and nuts.
2. Attach the coolant drain (6) to the chip tray using the 3 off M4 x 6mm (10) socket cap screws and M4 washers (11).
3. Attach the chip tray (5) using the 4 off M10 x 16mm Socket Head cap screws (7), M10 spring washer (8) and M10 washers (9).
4. Tighten all the nuts and bolts.

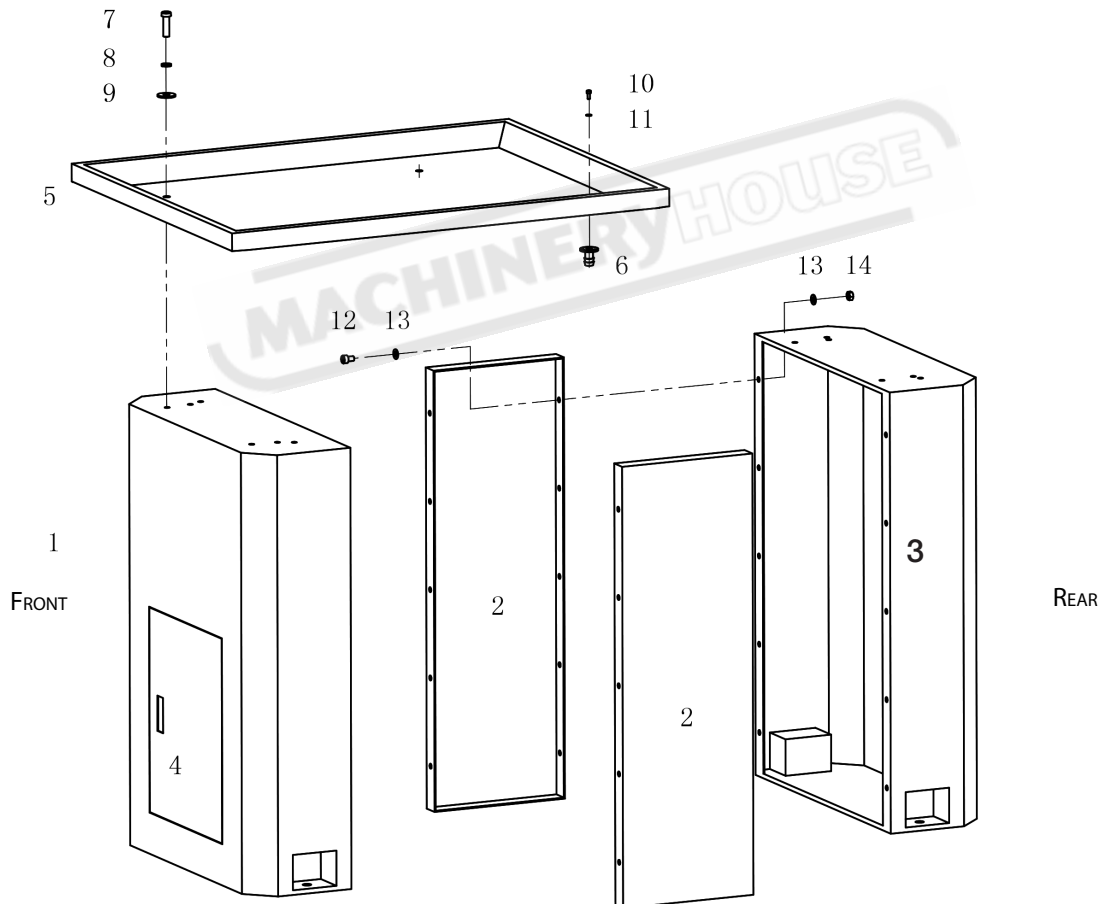



FIG. 4.5

The machine must be fully assembled before it can be operated. First clean any parts that are coated in rust preventative to ensure the assembly process can proceed smoothly.

Except for the hand-wheel handles, the mill/drill was fully assembled at the factory. Use a slotted screwdriver to attach the hand-wheel handles, to the "X" and "Y" axis handles.

4.7 BASIC CONTROLS

The descriptions below can be used to gain a basic understanding of the control panel to complete the test run

 **FORWARD BUTTON:** Starts clockwise spindle rotation (as viewed from above). The spindle must be completely stopped before this button is pushed.

 **REVERSE BUTTON:** Starts counter-clockwise spindle rotation (as viewed from above). The spindle must be completely stopped before this button is pushed.

 **POWER LAMP:** Illuminates when the machine is connected to power.

 **STOP BUTTON:** Stops spindle rotation.

MODE TOGGLE SWITCH: Selects either Milling and Drilling or Tapping mode. When tapping is selected the spindle reverses when it reaches the depth stop. Middle position is stop.

 **COOLANT SWITCH:** Switches the coolant pump on or off.

EMERGENCY STOP BUTTON: Cuts power to the spindle motor and remains depressed until reset. Twist clockwise until it pops out to reset. (Fig. 4.8)

 **ELEVATION SWITCH:** Rapid travel to raise or lower the head on the Z axis. (Fig. 4.7)

HIGH/LOW RANGE LEVER: Selects either high or low spindle speed range. (A in Fig. 4.9)

SPINDLE SPEED LEVER: Selects one of three spindle speeds in the selected speed range. (B in Fig. 4.9)

HM-48B



4.8 TEST RUN

NOTE: The headstock oil reservoir must have the proper amount of oil in it before the mill/drill can be operated for the first time. Damage caused by running the mill/drill without oil in the reservoir will not be covered under warranty.

Test run the machine to ensure it is properly connected to power and safety components are functioning correctly. If you find an unusual problem during the test run, immediately stop the machine, disconnect it from power, and fix the problem BEFORE operating the machine again. Consult the Troubleshooting table in the maintenance section of this manual for possible solution. The Test Run consists of verifying the following:

- 1) The motor powers up and runs correctly, and
- 2) the safety disabling mechanism on the emergency stop button works correctly.

To test run the mill/drill:

1. Clear all setup tools away from machine.
2. Connect machine to power supply. Power lamp should light.
3. Press EMERGENCY STOP button (E in Fig.4.10)
This will help prevent unexpected start-up when machine is connected to power
4. Shift high/low range lever (F) right to “L” and spindle speed lever (G) left to “2”. This selects a spindle speed of 180 RPM (refer to spindle speed chart on headstock).

Note: You may need to rotate spindle back and forth by hand while putting pressure on the shift lever to allow gears to mesh.

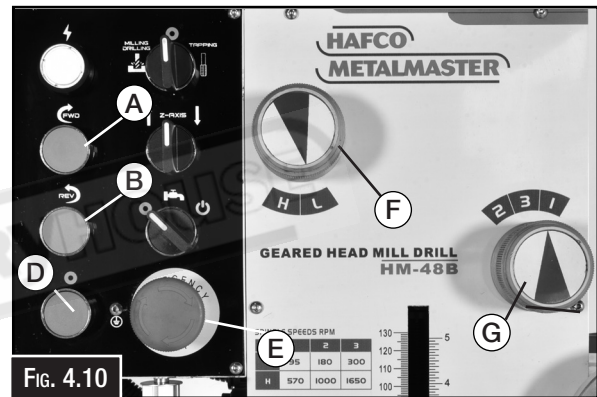

Fig. 4.10

5. Close the chuck guard
6. Twist EMERGENCY STOP button (E in Fig 4.10) clockwise until it pops out - this resets the button and enables the power to control panel and motor.
7. Press the SPINDLE FORWARD button (A in Fig 4.10). Spindle should rotate clockwise (as viewed from top) and machine should run smoothly with little to no vibration or rubbing noises.
8. Press STOP button (D in Fig. 4.10) and wait for spindle to completely stop.
9. Press SPINDLE REVERSE button.(B in Fig.4.10) Spindle should rotate counter-clockwise (as viewed from top).
10. Press EMERGENCY STOP button (E in Fig. 4.10) and wait for spindle to completely stop.
11. Without resetting EMERGENCY STOP button, press SPINDLE FORWARD button. Machine should not start.

NOTE: If the machine does start (with EMERGENCY STOP button pushed in), immediately disconnect the power to machine. EMERGENCY STOP safety feature is not working correctly. This safety feature must work properly before proceeding with regular operations. Refer to Troubleshooting on Page 24 for possible solution.

12. Twist EMERGENCY STOP button clockwise to reset it.
13. Start the machine again and then open the chuck guard. The machine should stop.
Once everything is working as it should then the Test Run is complete and the machine can be used for normal operation.

5. OPERATION.

5.1 OPERATION OVERVIEW

The purpose of this overview is to provide the novice machine operator with a basic understanding of how the machine is used during operation, so the machine controls/components discussed later in this manual are easier to understand.

Due to the generic nature of this overview, it is not intended to be an instructional guide. To learn more about specific operations, read this entire manual and seek additional training from experienced machine operators, and do additional research outside of this manual by reading “how-to” books, trade magazines, or visiting websites.

When undergoing a typical operation, the operator needs to do the following:

1. Examines the workpiece to make sure it is suitable for the machining operation.
2. Check the machine to ensure that it is safe to use and put on protective clothing and safety equipment.
3. Place the workpiece on the table and securely clamp it to the table.
4. Select the correct cutting tool for the job and with the machine disconnected from power, install the cutting tool using the correct holder.
5. Lower the headstock so the cutting tool is just above the workpiece. Uses the manual down feed controls to make the final adjustment.
6. Set the digital depth stop and the mini digital quill scale to the required units of measurement.
6. Select the correct spindle speed for the cutter and the workpiece.
7. Connect the machine to the power supply and turn it ON.
8. Lock the headstock and the required table locks in place.
9. Make sure the cutter clears the clamps and the work piece the, press the start button and begin milling, drilling, or tapping.
10. Uses the down feed, or table controls to perform the cutting operation.
11. Turn the machine OFF and wait for the spindle to completely stop before taking a measurement, removing the workpiece, changing tooling, or changing spindle speeds.

Visit machineryhouse.com.au or machineryhouse.co.nz for a full comprehensive range of tooling and accessories.

5.2 HEADSTOCK Z-AXIS MOVEMENT

The headstock is designed to move up and down along the Z axis

To Raise or Lower the Headstock Manually

1. DISCONNECT THE MACHINE FROM THE POWER!
2. Loosen both Z-axis lock levers shown in Fig.5.1



FIG. 5.1

3. Use the Z-axis crank shown in Fig.5.2 to adjust the headstock height.
4. Tighten Z-axis lock levers to secure the head.

NOTE: The elevation crank for the Z- axis should only be used to position the head and not as a feed option.



FIG. 5.2

Power Raise or Lower the Headstock

1. Loosen both Z-axis lock levers shown in Fig.5.3 and remove the crank handle.

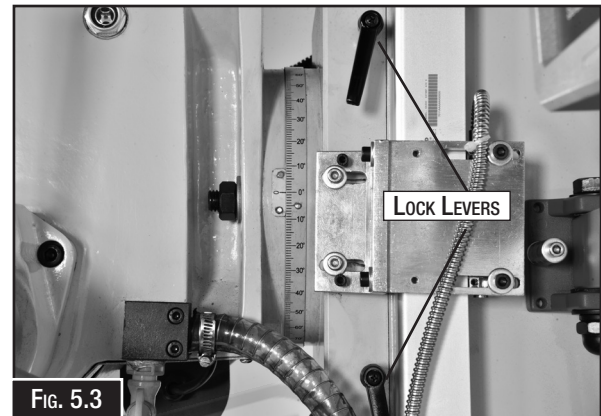

FIG. 5.3

2. Switch the "Z" axis switch to raise or lower the head. (D in Fig. 5.4)
3. Once in position then the Z-axis locks should be tightened.



FIG. 5.4

NOTE: The elevation switch for the Z- axis should only be used for positioning the head and not as a feed option.

WARNING Always remove the Z-axis crank before using the switch on the control panel.

5.3 TILTING THE HEAD

The headstock is designed to tilt up to 90 degrees left or right, relative to the table.



WARNING

The head is heavy and will require support when tilting. Arrange for some help to support the head when tilting.

To Tilt The Headstock

1. DISCONNECT THE MACHINE FROM THE POWER!
2. Loosen the three locking hex nuts a 1/4 to 1/2 a turn. There is one on either side of the head (Fig. 5.5) and one under the bottom of the head (see Fig. 5.6).

NOTE: The 3 nuts must only be loosened a quarter to a half a turn maximum to avoid the head disengaging from the tilting mechanism and the head dropping under its own weight.

3. Using the head angle scale shown (Fig.5.7) as a guide, or for a more accurate reading use the angle block digital gauge as shown (Fig.5. 8)
4. Swivel the headstock to the desired angle then re-tighten the three hex nuts to secure it.

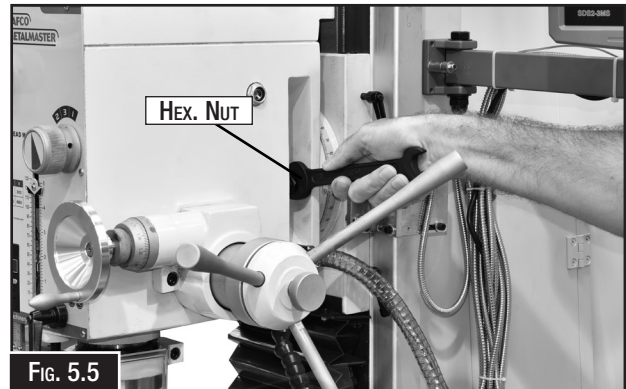

FIG. 5.5

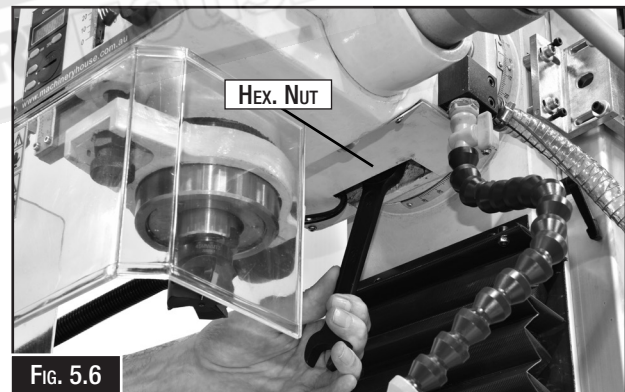

FIG. 5.6

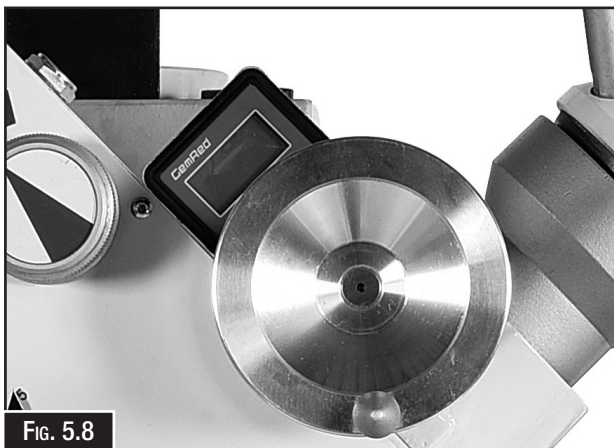

FIG. 5.8

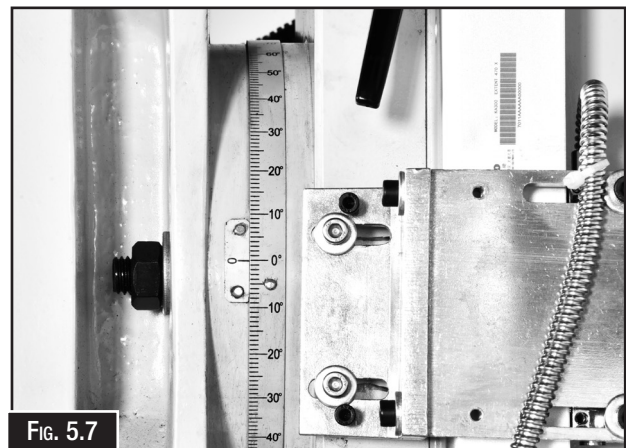

FIG. 5.7

5.4 DOWN- FEED CONTROLS

These machines are equipped with a course down-feed control mainly used for drilling or quick adjustment and a fine down-feed control, used mainly when milling or where controlled down feed is required. (Fig. 5.9)

- A. Depth Stop and Scale
- B. Quill Lock Lever
- C. Depth Stop Adjustment Knob
- D. Fine Down-feed Hand-wheel
- E. Down-feed Selector Knob
- F. Coarse Down-feed Handle

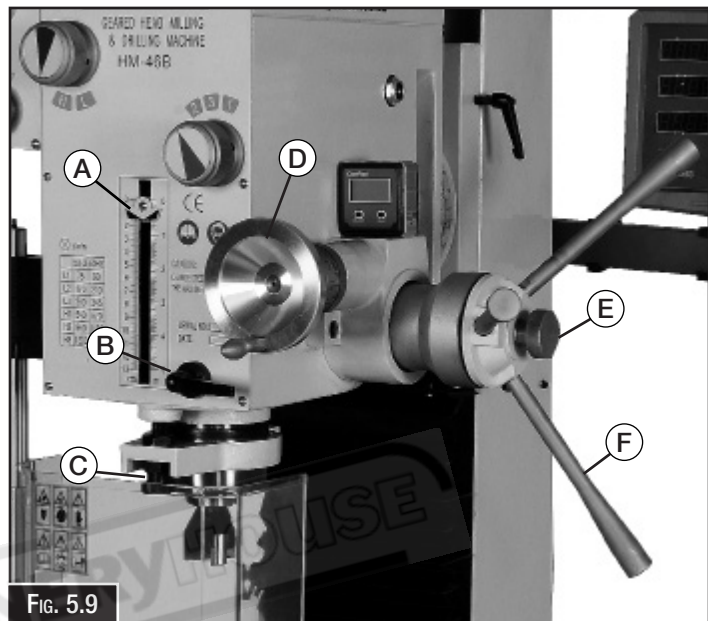

Fig. 5.9

To Use The Coarse Down-feed

1. Loosen quill lock lever.
2. Loosen down-feed selector knob to engage coarse down-feed handles.
3. Position depth stop with adjustment knob.
4. Use coarse down-feed handles to raise and lower the spindle.

Depth Stop

The depth stop limits the downward movement of the cutting tool. With the use of the depth stop adjustment knob (see "C" in Fig. 5.10), it can be positioned anywhere within 0–125mm. This is useful when performing the same operation multiple times.

To Use The Fine Down-feed

1. Loosen quill lock lever.
2. Tighten down-feed selector knob to engage fine down-feed hand wheel.
3. Position depth stop with adjustment knob.
4. Rotate fine down-feed hand wheel to raise and lower spindle.



Fig. 5.10

5.5 SETTING UP FOR TAPPING

The Hafco Metalmaster machines are fitted with a Tapping mode. When selected the spindle turns clockwise until it comes up against a micro switch in the depth stop which will bring the spindle to a complete stop and then reverse the spindle. The feed of the tap is by hand using the course down feed with handles.

To Use The Tapping Mode:

1. DISCONNECT THE MACHINE FROM POWER!
2. Install the tap, into a tapping chuck and bring it down until it touches the top of the hole to be tapped. Select the maximum tapping depth on the depth gauge, (Fig. 5.11) making sure that the tap does not bottom out.
3. Adjust the depth stop by turning the knurled knob (C in Fig. 5.12) accordingly.
4. Apply some tapping fluid to the contact point of the tap and to the workpiece.
5. Connect the machine to power.
6. Select the “tapping” mode with the drilling/tapping switch on the control panel (Fig. 5.13)
7. Select the appropriate spindle speed. Speeds vary according to the type of material of the work piece, the tap, and the procedure. There are several on-line resources to choose from for calculating the spindle speed.
8. Using the course feed handles, slowly lower the tap into the drilled hole, applying enough pressure for the tap to start cutting.

NOTE: A tapping chuck is required to use the tapping function (Order Code T004B)

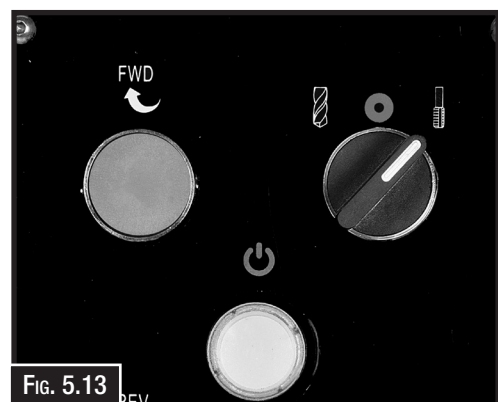
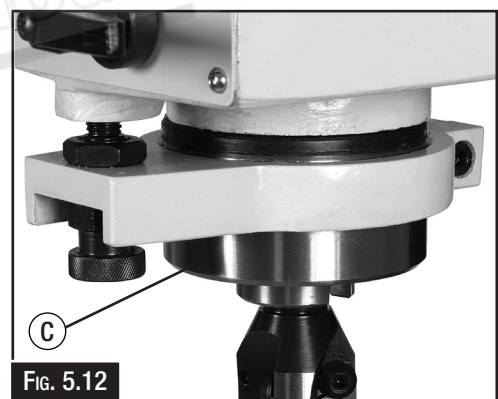

5.6 TABLE MOVEMENT

The table has travel in two directions called “X” and “Y” axis

X Axis is the Longitudinal Travel

Y Axis is the Cross Travel

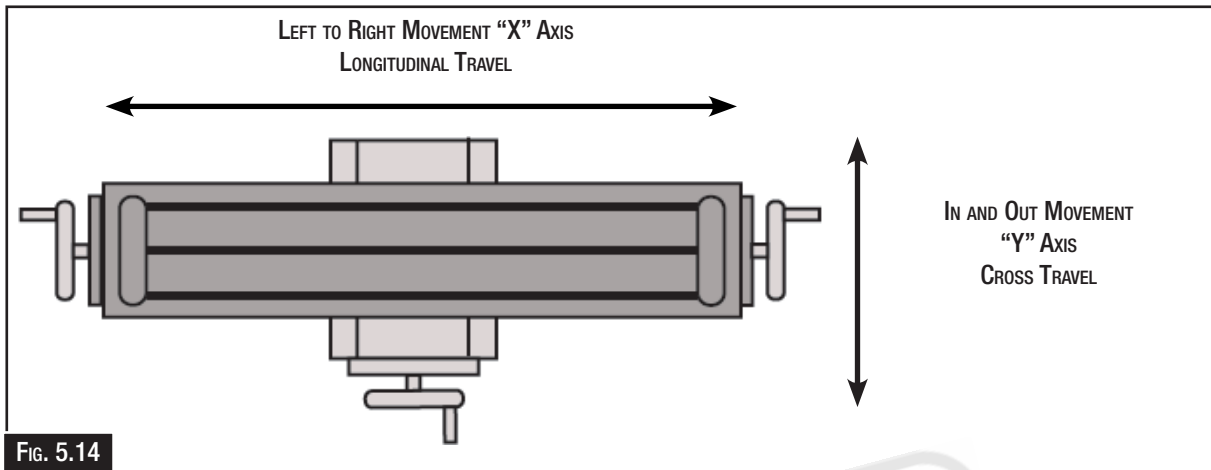

Fig. 5.14

GRADUATION DIALS

The hand-wheels have graduated dials that are used to determine table movement in 0.05mm increments, with one full revolution equalling 0.30mm

A thumb screw provides so the graduated dial can be adjusted to a relative starting point. (Fig. 5.15 & 5.16)

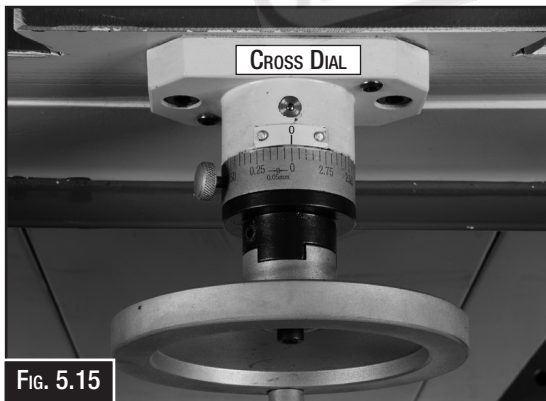

Fig. 5.15

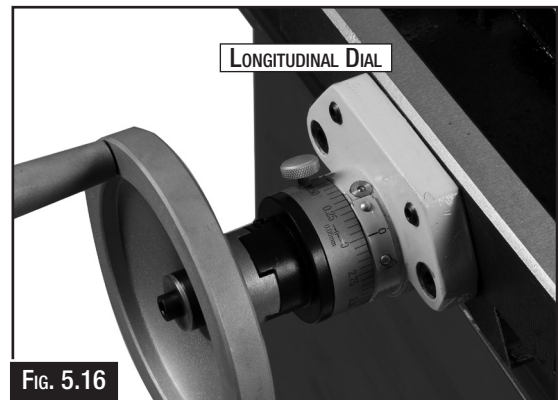

Fig. 5.16

Before moving the table make sure that the table lock for that movement has been unlocked. Always lock the table if not using the movement in that direction. (Fig. 5.17)

NOTE: When tightened, table locks provide table rigidity in that path of table travel for increased precision.

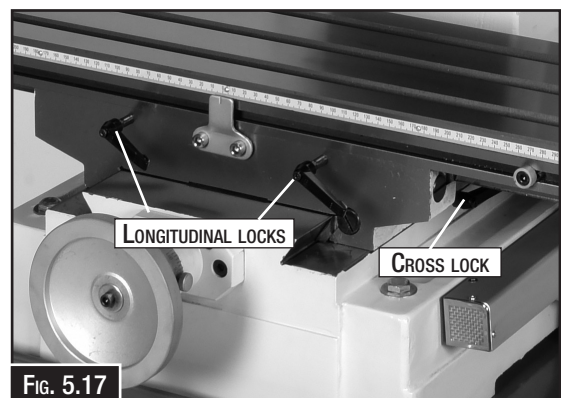

Fig. 5.17

5.7 INSTALLING & REMOVING THE TOOLING

The machine is fitted with a 3MT spindle to hold the tooling. While the taper will hold drills where pressure is applied to the end of the drill, with milling cutters pressure is applied to the side of the cutter, therefore the cutter arbour needs to be held also with a drawbar.

To install the tooling:

1. DISCONNECT THE MACHINE FROM POWER!
2. Remove the drawbar cap, so the drawbar is exposed. (Fig. 5.18)
3. Clean the mating surfaces then insert the tooling in the spindle with force so that the taper holds the arbour.
4. Select the correct drawbar thread that suits your tooling, then working from the top of the spindle, thread the drawbar by hand into the tooling until it is snug, then use a spanner to tighten it.
5. Replace the drawbar cap



Fig. 5.18

NOTE: Height of drawbar inside spindle can be changed by rotating adjustment nut. Do not over tighten the drawbar. Over tightening makes the tool removal difficult and may cause damage to the arbour and threads.

To remove the tooling:

1. DISCONNECT THE MACHINE FROM POWER!
2. Remove the drawbar cap.
3. Un-thread the drawbar from tooling one full rotation.

NOTE: Do not fully un-thread the tooling from the drawbar, or the drawbar and tool threads could be damaged in the next step.

4. Tap the top of drawbar with hammer to unseat the taper.
5. Hold onto the tooling with one hand and fully un-thread the drawbar. (Fig. 5.19)



Fig. 5.19

5.8 CHANGING THE SPEEDS

Selecting the correct spindle speed is important for safe and satisfactory results, as well as maximizing tool life.

To set the spindle speed for your operation, you will need to:

1. Determine the best spindle speed for the cutting task,
2. Configure the spindle speed levers to produce the required spindle speed.

Determining Spindle Speed

Many variables affect the optimum spindle speed to use for any given operation, but the two most important are the recommended cutting speed for the workpiece material and the diameter of the cutting tool, as noted in the formula. (Fig. 5.20)

Cutting speed, typically is defined in meters per minute (M/Min), is the speed at which the edge of a cutting tool moves across the material surface.

A recommended cutting speed is an ideal speed for cutting a type of material in order to produce the desired finish and optimize tool life.

$$(RPM) = \frac{\text{CUTTING SPEED M/MIN} \times 1000}{\text{CUTTER DIAMETER} \times 3.14}$$

Fig. 5.20

Books such as Fitting and Machinery Technical Manual (L341) or Machine Shop Practice, and some Internet sites, provide excellent recommendations for which cutting speeds to use when calculating the spindle speed. These sources also provide a wealth of additional information about the variables that affect cutting speed and they are a good educational resource.

Also, there are a large number of easy-to-use spindle speed calculators that can be found on the Internet. These sources will help you take into account the applicable variables in order to determine the best spindle speed for the operation.

SETTING THE SPINDLE SPEED

Use the chart or the one on the headstock when setting the spindle speed. The spindle must be stopped before the change gears can be moved.

With the spindle completely stopped, position the high/low range and spindle speed levers according to the chart. (Fig. 5.21)

	1	2	3
L	95	180	300
H	570	1000	1650



5.9 DIGITAL SPINDLE HEIGHT GAUGE

The digital spindle height scale (Fig.5.22) displays spindle position and movement. An auto shut-off feature will turn the unit OFF after several minutes of idle time. When turned back ON, the last measurement is recalled so work can be resumed. However, if the battery is changed or becomes discharged, the stored value is lost.

- A. **Digital Spindle Height Display:** Displays the spindle position and movement with a resolution of 0.01mm (0.0005").
- B. **ZERO Button:** Zeros the digital spindle scale at any point along its stroke.
- C. **mm/inch Button:** Toggles units of measure between metric and inch conventions.
- D. **OFF/ON Button:** Turns the digital height gauge ON or OFF.

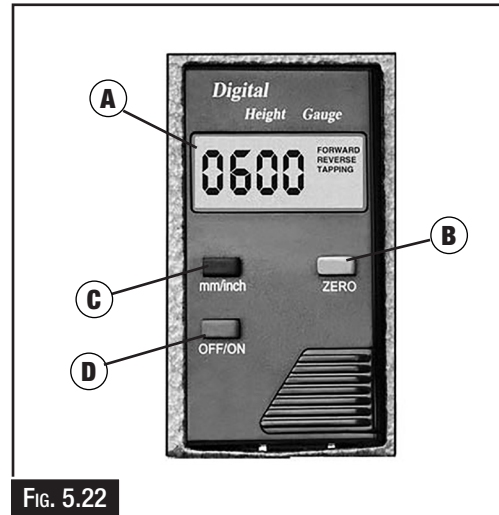

Fig. 5.22

5.10 POWER FEED UNIT

Use Fig. 5.23, & 5.24 along with the following descriptions, to become familiar with the power feed controls.

- A. **Reset Button:** Resets the circuitry if overloaded
- B. **Direction Lever:** Controls direction of powered table travel.
- C. **Rapid Switch:** When held down, moves table rapidly in chosen direction.
- D. **Power Light:** Lights when unit is connected to power.
- E. **Speed Dial:** Controls rate of power feed.
- F. **ON/OFF Switch**
- G. **X-Axis Limit Stops:** Adjustable along front of table to restrict X-axis table movement, particularly when using the power feed.
- H. **Limit Switch:** Stops power feed when contacted by a limit stop.

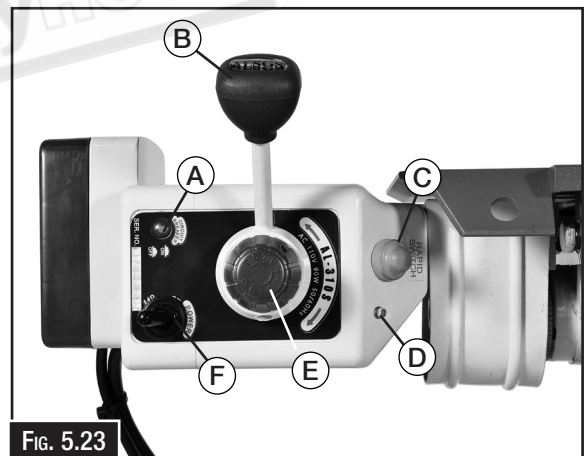

Fig. 5.23

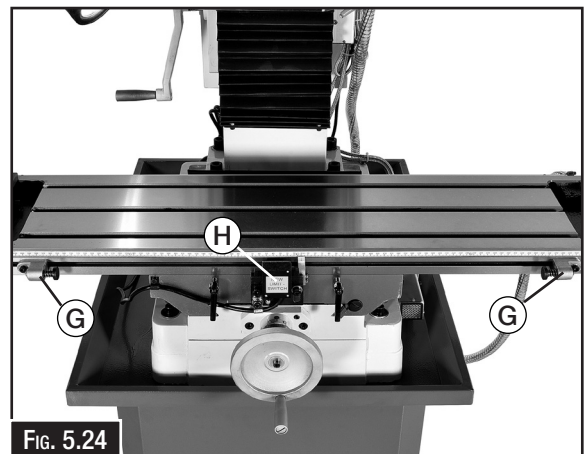
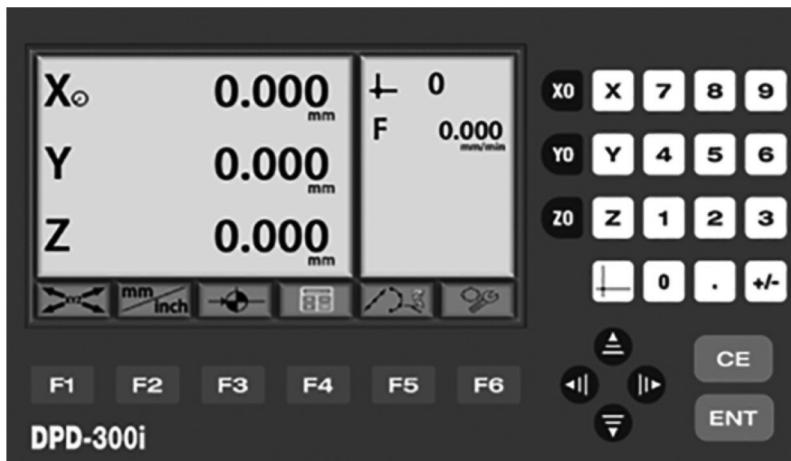

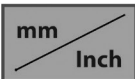

Fig. 5.24



5.11 HAFCO DIGITAL READOUT



NOTE: The digital display area of the front panel is not touch sensitive and any option on the screen requires an entry by a button.

Example:

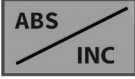
To select  press the button below 

To select  press the button below 

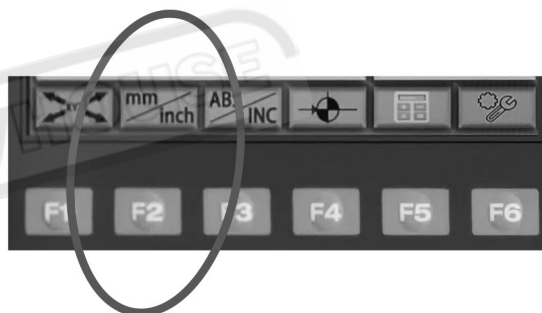

FUNCTION OPTIONS

The following copy of the Function Menu display and table of contents is a list of available Function Options for the DPD-300i Digital Readout.



Press the right or left arrows to change between the menu



THE FRONT PANEL IDENTIFICATION

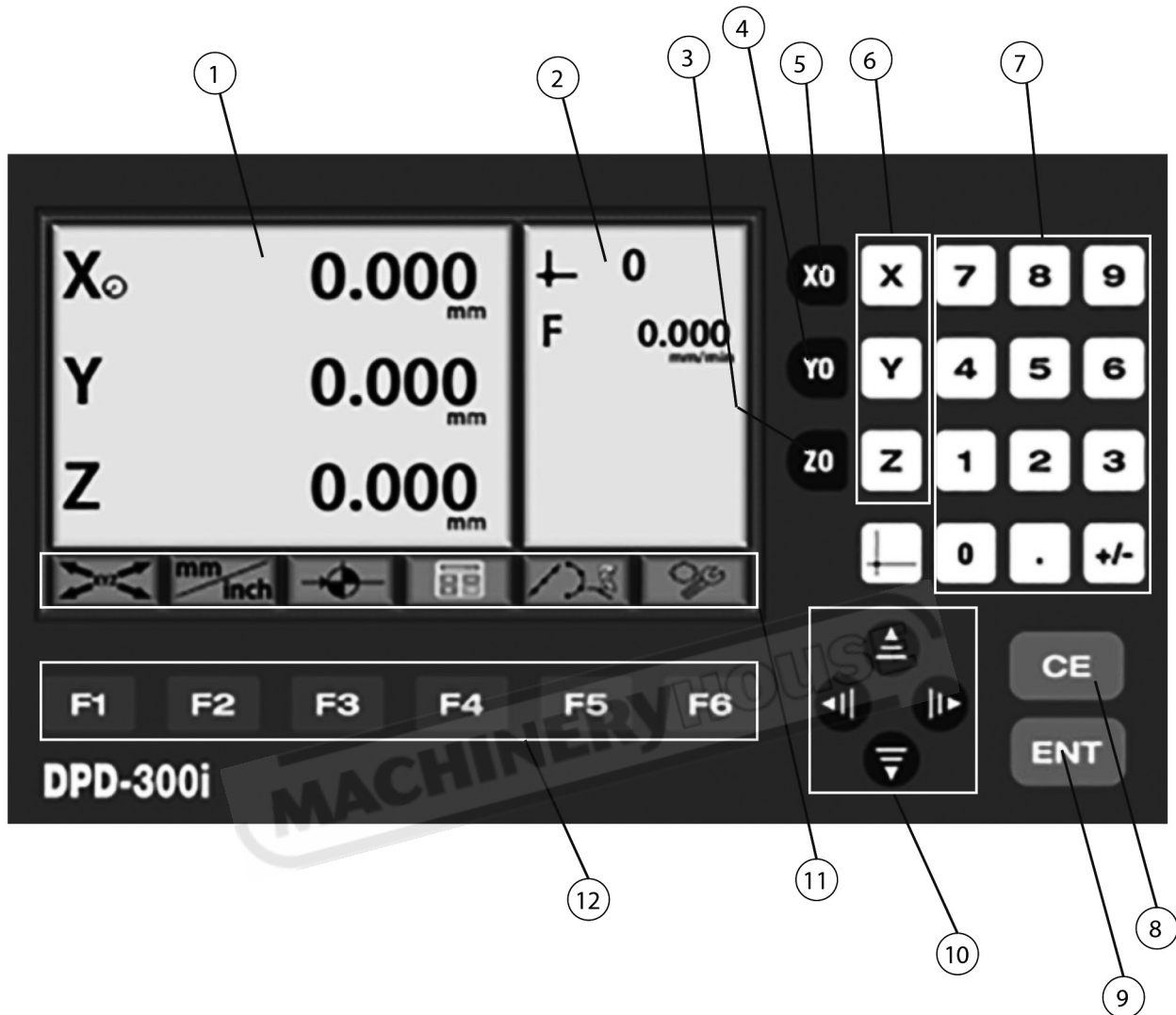

1	LCD Screen: Axis Display Section	7	Numeric Keys 1 ~ 0, Decimal Point and + and - Selection
2	Operation Function: Information	8	CE Key: Clears the operation selected
3	Z0 Zero's the Z axis (0.000)	9	ENT Key: Confirms selected operation
4	Y0 Zero's the Y axis (0.000)	10	Arrow Keys: Moves the Cursor around the LCD
5	X0 Zero's the X axis (0.000)	11	Function Options: Displays Options available.
6	X, Y, Z Keys: Select each Axis when changes need to be made.	12	Select Function Keys F1 - F6: Selects the function directly above the key

**FOR THE COMPLETE HAFCO DIGITAL READOUT MANUAL DOWNLOAD FROM MD-46B
www.machineryhouse.com.au**

6. MAINTENANCE

6.1 LUBRICATION:

All ball bearings in your mill/drill are sealed for life, requiring no lubrication.

Points requiring lubrication are:

1. Internal spline drive assembly. Keep this area well lubricated with a good grade grease, insert grease in the hole at the top of spindle pulley spline driver, lube **TWICE YEARLY**.
2. A light film of oil applied to the quill, table and column will reduce wear, prevent rust, and assure ease of operation. **EVERY 30 DAYS**. Fluid Film (O040 or O043)
3. Quill return spring should receive oil (SAE 20) **ONCE YEARLY**. Remove cover plate and apply oil with oil can or small brush.
4. IMPORTANT: The gear box should be filled with oil such as SAE 68 to the level in the sight glass. **CHANGE OIL EVERY 12 MONTHS**.
5. Apply oil to quill pinion **EVERY 90 DAYS**.

NOTE: Use extreme care when performing these operations and keep hands clear of pinch points. Do not apply with motor running.

6.2 CHANGING THE GEAR BOX OIL

The headstock oil should be changed every 12 months.

To Change The Oil.

1. Run the spindle for 5 or 10 minutes at 570rpm to warm the oil
2. DISCONNECT THE MACHINE FROM THE POWER
3. Open the drain plug to allow the oil to drain from the opening completely. (Fig. 6.1)
4. Replace the oil drain plug and remove the oil filler plug, and fill the gearbox with oil until the oil level reaches the middle of the oil fluid lever indicator. (Fig. 6.2)
5. Then replace the oil filler plug.

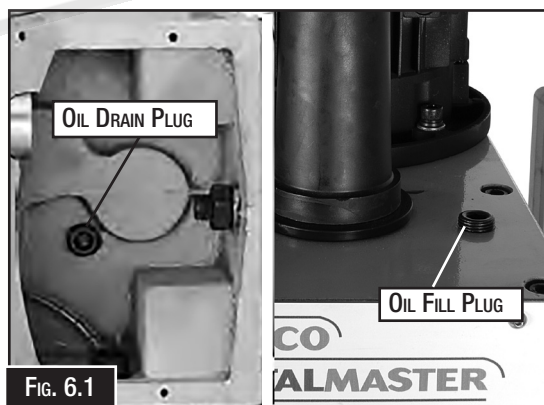

Fig. 6.1

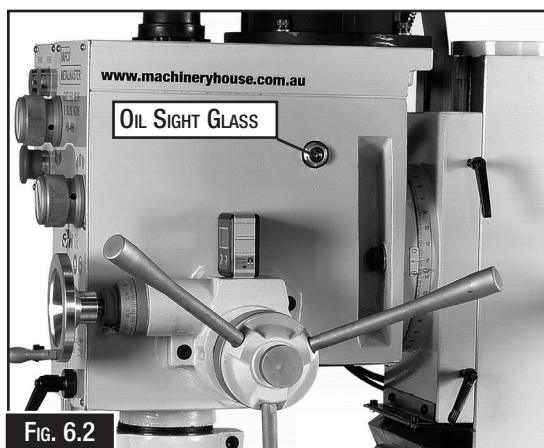

Fig. 6.2

6.3 GIB ADJUSTMENT

Gibs are tapered lengths of metal that are sandwiched between two moving surfaces. Gibs control the gap between these surfaces and how they slide past one another. Correctly adjusting the gibs is critical to producing good milling results.

Tight gibs make table movement more accurate but stiff. Loose gibs make moving the table sloppy but easier to do. The goal of gib adjustment is to remove unnecessary sloppiness without causing the ways to bind.

Gibs are adjusted with a screw on each end of the gib, that move the tapered gib back-and-forth to increase or decrease the friction pressure between the sliding surfaces. The process of properly adjusting the gibs requires trial-and-error and patience.

Refer to Fig. 6.3-6.5 to identify the locations of the table, saddle, and column gibs, and one of the two adjustment screws for each.

NOTE: It will be necessary to remove small parts, such as way wipers and covers, to access the gib adjustment screws.

The following is the method used to adjust the gibs.

1. DISCONNECT MACHINE FROM POWER!
2. Make sure all table/column locks are loose.
3. Loosen one gib adjustment screw, then tighten the other the same amount to move the gib.
4. Use the handles/crank to move table/head until you feel a slight drag in the path of movement. Repeat Steps 3-4 as necessary.

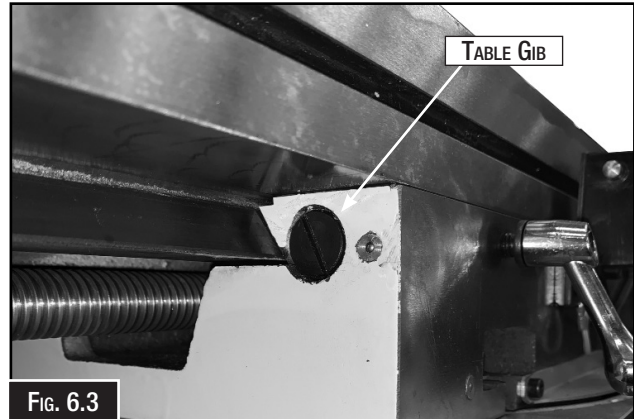

FIG. 6.3



FIG. 6.4

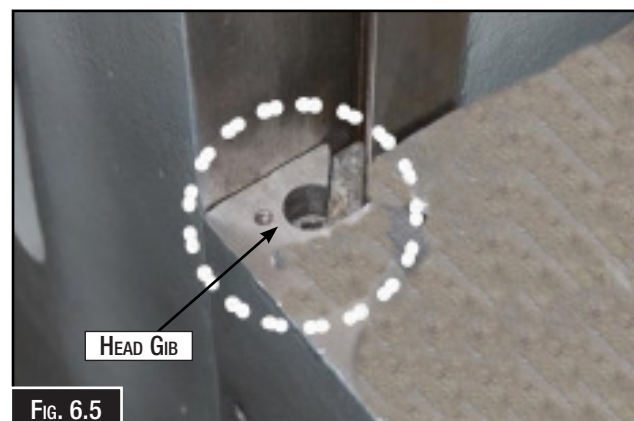

FIG. 6.5

6.4 TROUBLESHOOTING

Symptom	Possible Cause	Possible Solution
Tool loose in spindle.	<ol style="list-style-type: none"> 1. Tool is not fully drawn up into spindle taper. 2. Debris on tool or in spindle taper 3. Taking too big of a cut. 	<ol style="list-style-type: none"> 1. Tighten drawbar. 2. Clean tool and spindle taper. 3. Lessen depth of cut and allow chips to clear.
Breaking tools or cutters.	<ol style="list-style-type: none"> 1. Spindle speed/feed rate is too fast. 2. Cutting tool is too small. 3. Cutting tool getting too hot. 4. Taking too big of a cut. 5. Spindle extended too far down. 	<ol style="list-style-type: none"> 1. Set spindle speed correctly or use slower feed rate 2. Use larger cutting tool and slower feed rate. 3. Use coolant or oil for appropriate application. 4. Lessen depth of cut and allow chips to clear. 5. Fully retract spindle and raise table. This increases rigidity.
Workpiece or tool vibrates or chatters during operation.	<ol style="list-style-type: none"> 1. Table locks not tight. 2. Workpiece not secure. 3. Spindle speed/feed rate is too fast. 4. Spindle extended too far down 5. Quill lock lever not tight. 6. Gibs too loose in table. 	<ol style="list-style-type: none"> 1. Tighten table locks. 2. Properly clamp workpiece on table or in vise. 3. Set spindle speed correctly or use slower feed rate (Page 20). 4. Fully retract spindle and raise table This increases rigidity. 5. Tighten quill lock lever. 6. Tighten gibs.
Table is hard to move.	<ol style="list-style-type: none"> 1. Table locks are tightened down. 2. Chips have loaded up on ways. 3. Ways are dry and need lubrication. 4. Table limit stops are interfering. 5. Gibs are too tight. 	<ol style="list-style-type: none"> 1. Fully release table locks . 2. Frequently clean away chips or debris. 3. Lubricate ways. 4. Make sure that table limit stops are not in the way 5. Adjust gibs .
Headstock is hard to raise.	<ol style="list-style-type: none"> 1. Headstock lock(s) or gib is at fault. 2. Headstock leadscrew is binding. 3. Gib is too tight. 	<ol style="list-style-type: none"> 1. Loosen/replace lock lever and adjust gib 2. Clean and relubricate headstock leadscrew and gears 3. Adjust gib.
Bad surface finish	<ol style="list-style-type: none"> 1. Spindle speed/feed rate is too fast. 2. Dull or incorrect cutting tool. 3. Wrong rotation of cutting tool 4. Workpiece not secure. 5. Spindle extended too far down. 	<ol style="list-style-type: none"> 1. Set spindle speed correctly or use slower feed rate (Page 20). 2. Sharpen cutting tool or select one that better suits the operation. 3. Check for proper cutting tool rotation. 4. Properly clamp workpiece on table or in vise. 5. Fully retract spindle and raise table. This increases rigidity.
Cutting results not square.	<ol style="list-style-type: none"> 1. Table and spindle are not at 90° to each other. 2. Table travel is inconsistent 	<ol style="list-style-type: none"> 1. Square the spindle. 2. Adjust gibs .
Spindle overheats.	<ol style="list-style-type: none"> 1. Poor spindle bearing lubrication. 2. Spindle bearings too tight. 3. Mill operated at high speeds for extended period. 	<ol style="list-style-type: none"> 1. Replace spindle bearings. 2. Properly adjust spindle bearing preload. 3. Allow mill to cool.
Noisy Operation	<ol style="list-style-type: none"> 1. Faulty Motot 2. Faulty Bearings 	<ol style="list-style-type: none"> 1. Replace or repair motor 2. Replace bearings.



WARNING

**Disconnect all power from the machine before servicing.
There may be multiple power sources present.
Remove the plug from the power point or remove the fuse if
hardwired. Failure to do may cause death or injury.**

MILL DRILL MACHINE HM-48B

Order Code: (K8742D)

Edition : 1.0
Date: (05/24)

The following section covers the spare parts diagrams and lists that were current at the time this manual was originally printed. Due to continuous improvements of the machine, changes may be made at anytime without notification.

HOW TO ORDER SPARE PARTS

1. Have your machines model number, serial number & date of manufacture on hand, these can be found on the specification plate mounted on the machine
2. A scanned copy of your parts list/diagram with required spare part/s identified.

NOTE: SOME PARTS MAY ONLY BE AVAILABLE AS AN ASSEMBLY

3. Go to www.machineryhouse.com.au/contactus and fill out the inquiry form attaching a copy of scanned parts list.



WARNING!

*Electricity is dangerous and could cause death
All electrical work must be carried out by a qualified electrician.*



CAUTION

It is impossible to cover all possible hazards Every workshop enviroment is different. These are designed as a guide to be used to compliment training and as a reminder to users prior to equipment use. Always consider safety first, as it applies to the individual working conditions.

SPARE PARTS HEAD DIAGRAM HM-48B

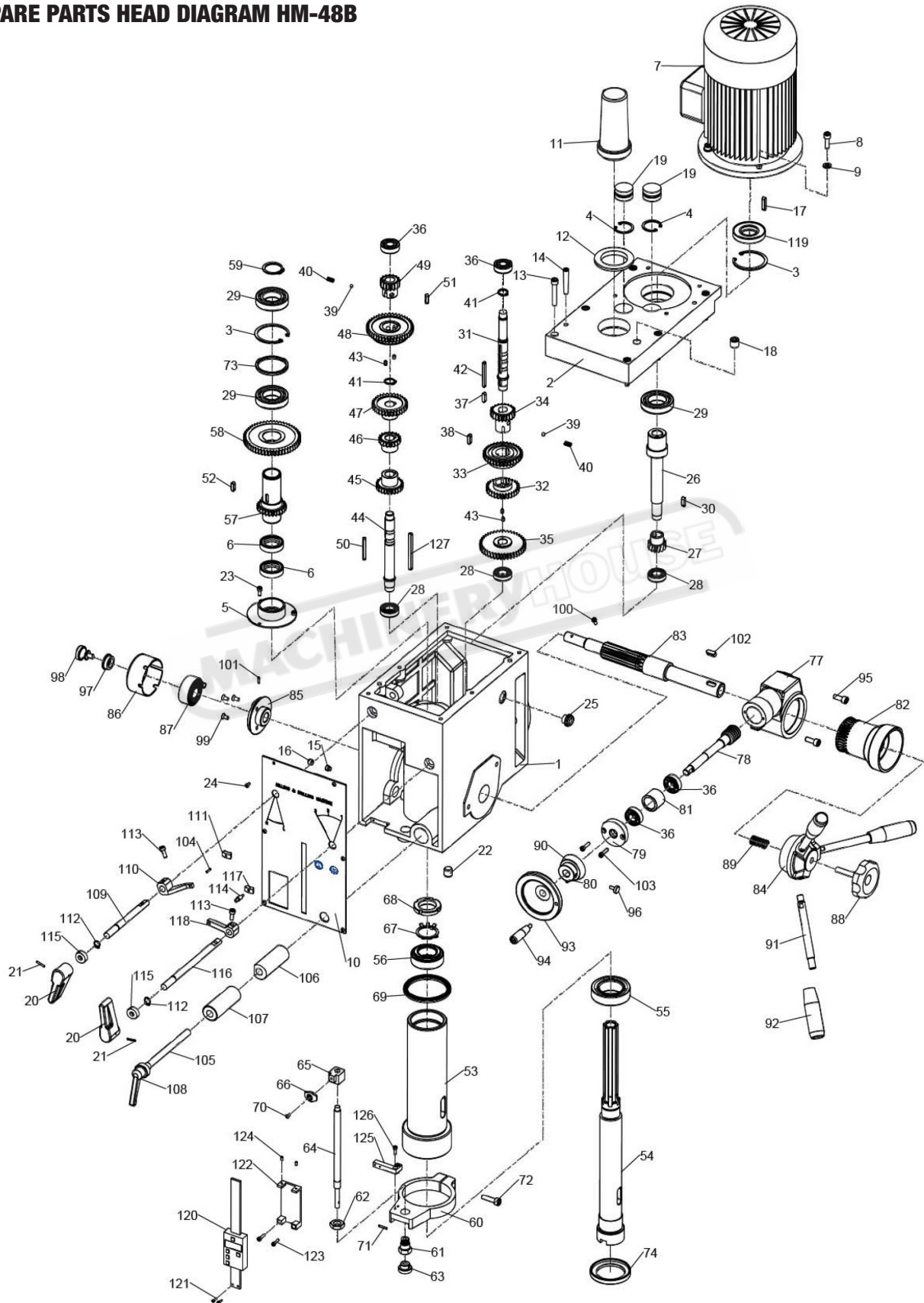

SPARE PARTS LIST FOR HEAD HM-48B

NO.	DESCRIPTION	SIZE	QTY	NO.	DESCRIPTION	SIZE	QTY
1	Head body	20010B	1	37	Key	6X14	1
2	Head Body Cover	20011B	1	38	Key	6X28	1
3	Int Retaining Ring	Ø62	2	39	Ball	Ø8	2
4	Int Retaining Ring	Ø35	2	40	Spring		2
5	Airtight Base	20018B	1	41	Ext Retaining Ring	Ø18	2
6	Airtight Ring	45x35X10	2	42	Key	5X50	1
7	Motor	1.5KW	1	43	Screw	M6X12	4
8	Screw	M8X25	1	44	lii Shaft	20107B	1
9	Washer	8	1	45	Gear Z25	20109-B	1
10	Plate	20201	1	46	Gear Z18	20110-2-B	1
11	Arbor Bolt Cover	20304-1B	1	47	Gear Z32	20112-B	1
12	Arbor Bolt Cover Base	20304-2B	1	48	Gear Z43	20113-B	1
13	Screw	M8X45	6	49	Gear Z16	20115-B	1
14	Pin	8x40	2	50	Key	5X50	1
15	Screw	M10x10	1	51	Key	6X18	1
16	Screw	M10x8	1	52	Key	6X18	1
17	Key	6X28	1	53	Spindle Sleeve	20019	1
18	Bolt	ZG3/8"	1	54	Spindle	20104B	1
19	Cap	20020B	2	55	Bearing	30207 /P5	1
20	Speed Lever	20307B	2	56	Bearing	30206 /P5	1
21	Pin	3X18	2	57	Splined Sleeve Z25	20114-B	1
22	Oil Plug	ZG3/8"	1	58	Gear Z53	20116-B	1
23	Screw	M5x10	3	59	Ext Retaining Ring	Ø35	1
24	Screw	M4X8	6	60	Feed Base	20012	1
25	Oil Pointer	M18X1.5	1	61	Support Base	20128	1
26	I Shaft	20105B	1	62	Nut	20129	1
27	Gear Z14	20105-1-B	1	63	Knob	20130	1
28	Bearing	6003 / P5	3	64	Graduated Rod	20131	1
29	Bearing	6007 / P5	3	65	Fixed Bolt	20021	1
30	Key	5X25	1	66	Scale Board	20132	1
31	li Shaft	20106B	1	67	Lock Washer	Ø30	1
32	Gear Z29	20108-B	1	68	Lock Nut	M30X1.5	1
33	Gear Z35	20110-1-B	1	69	Rubber Washer	20308	1
34	Gear Z21	20111-B	1	70	Screw	M4X8	1
35	Gear Z41	20106-1-B	1	71	Split Pin	3X18	1
36	Bearing	6202 / P5	4	72	Bolt	M8X30	1

NOTE: SOME INDIVIDUAL PARTS MAY ONLY BE AVAILABLE AS AN ASSEMBLY

SPARE PARTS LIST FOR HEAD HM-48B

NO.	DESCRIPTION	SIZE	QTY	NO.	DESCRIPTION	SIZE	QTY
73	Separating Ring	20024B	1	108	Adjust Handle		1
74	Bearing Cover	20133B	1	109	Lever Shaft	20125B	1
75	Screw (R8)	M5X6	1	110	Lever	20022-1B	1
76	Pin (R8)	M5X4	1	111	Lever Bracket	20204-2B	1
77	Worm Wheel Box	20015	1	112	Ext Retaining Ring	12	2
78	Worm Shaft	20119	1	113	Screw	M6X16	2
79	Worm Cover	20302	1	114	Lever Rod	20204-3B	1
80	Screw	M6X12	1	115	Oil Seal	12X22X8	2
81	Separating Ring	20120	1	116	Long Lever Shaft	20126B	1
82	Worm Wheel	20016	1	117	Lever Bracket	20204-1B	1
83	Pinion Shaft	20117	1	118	Lever	20022-2B	1
84	Handle Body	20013	1	119	Oil Seal	35x62x10	1
85	Spring Base	20118	1	120	Digital Display		1
86	Spring Cap	20123	1	121	Screw	M3X10	2
87	Spring Plate	20122	1	122	Stents	20010C2	1
88	Big Ripple Handle	20303	1	123	Screw	M4X16	2
89	Compression Spring		1	124	Screw	M4X10	2
90	Graduated Plate	20017	1	125	Connecting Rod	20010C3	1
91	Handle Rod	20121B	1	126	Screw	M4X12	2
92	Handle Ball	20301B	1	127	Key	6X70	1
93	Handle Wheel	20306B	1				
94	Handle Rod	20305-B	1				
95	Screw	M8X25	2				
96	Screw	10107	1				
97	Washer	203063	1				
98	Screw	203066	1				
99	Screw	M6X12	3				
100	Screw	M5X12	1				
101	Pin	3X12	2				
102	Key	8X20	1				
103	Screw	M5X20	2				
104	Pin	3X15	1				
105	Fixed Bolt	20124B	1				
106	Fixed Tight Block	20203B	1				
107	Fixed Tight Block	20202B	1				

NOTE: SOME INDIVIDUAL PARTS MAY ONLY BE AVAILABLE AS AN ASSEMBLY

TABLE & COLUMN SPARE PARTS DIAGRAM HM-48B

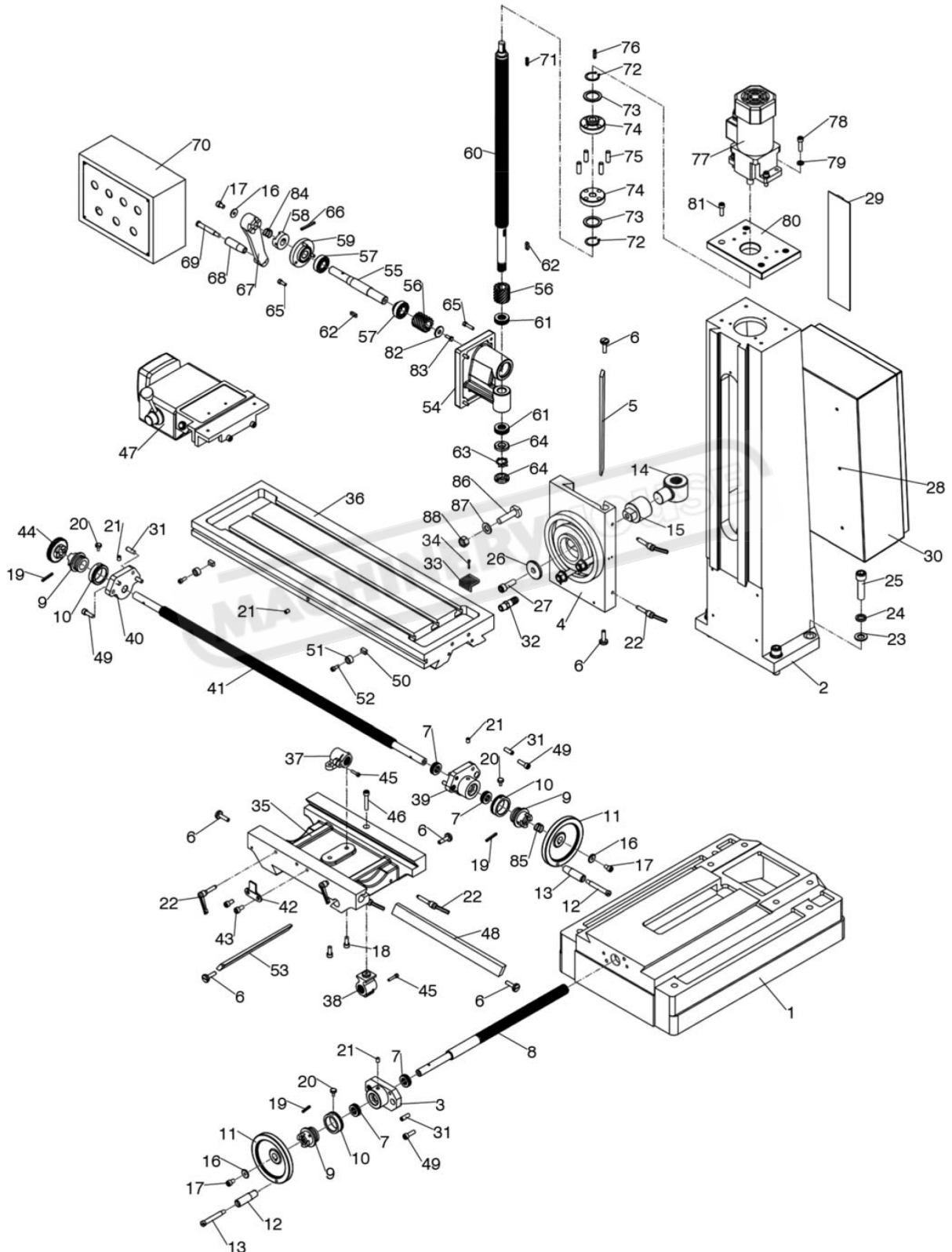

SPARE PARTS LIST FOR COLUMN & TABLE HM-48B

NO.	DESCRIPTION	SIZE	QTY	NO.	DESCRIPTION	SIZE	QTY
1	Base	10010	1	45	Screw	M5X20	2
2	Column	10013	1	46	Screw	M8X45	1
3	Square Flange	10021	1	47	Power Feed	135LBS	2
4	Raise And Lower Base	10016	1	48	Gib Strip	10022	1
5	Gib Strip	10025	1	49	Screw	M8X25	6
6	Screw	10106	6	50	Movable Fixed Block	10108	2
7	Bearing	51103	4	51	Fixed Block Support	10109	2
8	Table Screw	10104	1	52	Screw	M6X16	2
9	Dial Clutch	10102	3	53	Gib Strip	10023	1
10	Graduated Plate	10111	3	54	Raise & Lower Base	10017	1
11	Wheel	10301	2	55	Shaft	10113	1
12	Turn Handle	20305-1B	2	56	Gear	20109	2
13	Screw	20305-2B	2	57	Bearing	6004	2
14	Nut	10024	1	58	Dial Clutch	450209	1
15	Nut Bracket	10117	1	59	Flange	10015	1
16	Washer	6	3	60	Raise & Lower Screw	10016	1
17	Screw	M6X16	3	61	Bearing	51104	2
18	Screw	M8X25	2	62	Key	6 X 20	2
19	Pin	5X35	3	63	Lock Washer	20	1
20	Screw	10107	3	64	Lock Nut	M20X1.5	2
21	Oil Cup	8	4	65	Screw	M6 X 25	7
22	Fixed Handle	M8	6	66	Pin	5 X 40	1
23	Washer	16	4	67	Heaf Handle	10018	1
24	Washer	16	4	68	Turn Handle	10018.1	1
25	Bolt	M16X60	4	69	Screw M10	10018.2	1
26	Washer	10120	1	70	Electrical Box		1
27	Screw	M12X35	1	71	Key	5X22	1
28	Screw	M6x12	6	72	Retaining Ring	30	2
29	Protecting Cover	10124	1	73	Washer	10152	2
30	Electrical Box	10119	1	74		10150	2
31	Pin	8X30	6	75		10151	4
32	Pipe Joint		1	76	Key	5X25	1
33	Filter Screen		1	77	90w220v60hz1ph	Motor	1
34	Table Nut	M3X25	2	78	Screw	M8X25	4
35	Center Base	10011	1	79	Washer	M8	4
36	Table	10012	1	80	Motor Mount	10014	1
37	Table Nut	10202	1	81	Screw	M8 X 25	4
38	Table Base Nut	10203	1	82	Washer	M8	1
39	Right Flange	10020	1	83	Screw	M8 X 25	1
40	Left Flange	10019	1	84	Spring	450209.2	1
41	Table Screw	10103	1	85	Spring	10102.2	1
42	Fixed Block	10105	1	86	T-Screw	M14x55	3
43	Screw	M8x16	2	87	Washer	M14	3
44	Gear		1	88	Nut	M14	3

NOTE: SOME INDIVIDUAL PARTS MAY ONLY BE AVAILABLE AS AN ASSEMBLY

WARNING

General Machinery Safety Instructions

Machinery House
requires you to read this entire Manual before using this machine.

- 1. Read the entire Manual before starting machinery.** Machinery may cause serious injury if not correctly used.
- 2. Always use correct hearing protection when operating machinery.** Machinery noise may cause permanent hearing damage.
- 3. Machinery must never be used when tired, or under the influence of drugs or alcohol.** When running machinery you must be alert at all times.
- 4. Wear correct Clothing.** At all times remove all loose clothing, necklaces, rings, jewelry, etc. Long hair must be contained in a hair net. Non-slip protective footwear must be worn.
- 5. Always wear correct respirators around fumes or dust when operating machinery.** Machinery fumes & dust can cause serious respiratory illness. Dust extractors must be used where applicable.
- 6. Always wear correct safety glasses.** When machining you must use the correct eye protection to prevent injuring your eyes.
- 7. Keep work clean and make sure you have good lighting.** Cluttered and dark shadows may cause accidents.
- 8. Personnel must be properly trained or well supervised when operating machinery.** Make sure you have clear and safe understanding of the machine you are operating.
- 9. Keep children and visitors away.** Make sure children and visitors are at a safe distance for you work area.
- 10. Keep your workshop childproof.** Use padlocks, Turn off master power switches and remove start switch keys.
- 11. Never leave machine unattended.** Turn power off and wait till machine has come to a complete stop before leaving the machine unattended.
- 12. Make a safe working environment.** Do not use machine in a damp, wet area, or where flammable or noxious fumes may exist.
- 13. Disconnect main power before service machine.** Make sure power switch is in the off position before re-connecting.
- 14. Use correct amperage extension cords.** Undersized extension cords overheat and lose power. Replace extension cords if they become damaged.
- 15. Keep machine well maintained.** Keep blades sharp and clean for best and safest performance. Follow instructions when lubricating and changing accessories.
- 16. Keep machine well guarded.** Make sure guards on machine are in place and are all working correctly.
- 17. Do not overreach.** Keep proper footing and balance at all times.
- 18. Secure workpiece.** Use clamps or a vice to hold the workpiece where practical. Keeping the workpiece secure will free up your hand to operate the machine and will protect hand from injury.
- 19. Check machine over before operating.** Check machine for damaged parts, loose bolts, Keys and wrenches left on machine and any other conditions that may effect the machines operation. Repair and replace damaged parts.
- 20. Use recommended accessories.** Refer to instruction manual or ask correct service officer when using accessories. The use of improper accessories may cause the risk of injury.
- 21. Do not force machinery.** Work at the speed and capacity at which the machine or accessory was designed.
- 22. Use correct lifting practice.** Always use the correct lifting methods when using machinery. Incorrect lifting methods can cause serious injury.
- 23. Lock mobile bases.** Make sure any mobile bases are locked before using machine.
- 24. Allergic reactions.** Certain metal shavings and cutting fluids may cause an allergic reaction in people and animals, especially when cutting as the fumes can be inhaled. Make sure you know what type of metal and cutting fluid you will be exposed to and how to avoid contamination.
- 25. Call for help.** If at any time you experience difficulties, stop the machine and call you nearest branch service department for help.

WARNING

Milling Machine Safety Instructions

Machinery House
requires you to read this entire Manual before using this machine.

- 1. Maintenance.** Make sure the mill is turned off and disconnect from the main power supply and make sure all moving parts have come to a complete stop before any inspection, adjustment or maintenance is carried out.
- 2. Mill Condition.** Mill must be maintained for a proper working condition. Never operate a mill that has damaged or worn parts. Scheduled routine maintenance should be performed on a scheduled basis.
- 3. Leaving a Mill Unattended.** Always turn the mill off and make sure all moving parts have come to a complete stop before leaving the mill. Do not leave mill running unattended for any reason.
- 4. Avoiding Entanglement.** Remove loose clothing, belts, or jewelry items. Never wear gloves while machine is in operation. Tie up long hair and use the correct hair nets to avoid any entanglement with the mill spindle or moving parts.
- 5. Chuck key safety.** Always remove your chuck key, draw bar wrench, and any service tools immediately after use. Chuck keys left in the chuck can cause serious injury.
- 6. Understand the machines controls.** Make sure you understand the use and operation of all controls.
- 7. Tooling selection & holding.** Always use the correct cutting tool for the job you are milling. Make sure it is sharp and held firmly in place.
- 8. Cutting Tool inspection.** Inspect Drill and end mills for sharpness, chips, or cracks before use. Replace any cutting tools immediately if dull, chipped or cracked. Handle new cutting tools with care. Cutting edges are very sharp and can cause lacerations.
- 9. Reversing the spindle.** Make sure the spindle has come to a complete stop before changing the direction of the spindle. Do not slow or stop the spindle by using your hand.
- 10. Stopping the spindle.** Do not slow or stop the spindle by using your hand.
- 11. Speed selection.** Select the appropriate speed for the type of work, material, and tool bit. Allow the mill to reach full speed before beginning a cut.
- 12. Clearing chips.** Always use a brush to clear chips. Never clear chips when the mill is running.
- 13. Power outage.** In the event of a power failure during use of the mill, turn off all switches to avoid possible sudden start up once power is restored.
- 14. Clean work area.** Keep the area around the mill clean from oil, tools and chips.
- 15. Tilting head.** Use an assistant to help support the head correctly. Make sure bolts that secure the head for tilting are not loosened to much as head can slip and cause serious injury. Please refer to Mill head Tilting Instructions for correct procedure.
- 16. Call for help.** If at any time you experience difficulties, stop the machine and call your nearest branch service department for help.

PLANT SAFETY PROGRAM

NEW MACHINERY HAZARD IDENTIFICATION, ASSESSMENT & CONTROL

Milling Machine

Developed in Co-operation Between A.W.I.S.A and Australia Chamber of Manufactures
This program is based upon the Safe Work Australia, Code of Practice - Managing Risks of Plant in the Workplace (WHSA 2011 No10)



Item No.	Hazard Identification	Hazard Assessment	Risk Control Strategies <small>(Recommended for Purchase / Buyer / User)</small>
A	ENTANGLEMENT	HIGH	Eliminate, avoid loose clothing / Long hair etc.
B	CRUSHING	LOW	Secure & support workpiece on mill table.
B	CRUSHING	HIGH	Mill head tilting adjustment - please refer to mill head tilting instruction sheet for correct procedure.
C	CUTTING, STABBING, PUNCTURING	MEDIUM	Incorrect adjustment may result in the head becoming detached and a crushing hazard Isolate power to machine prior to any checks or maintenance being carried out. Do not adjust or clean machine until the machine has fully stopped.
D	SHEARING	MEDIUM	Make sure all guards are secured shut when machine is on. Isolate power to machine prior to any checks or maintenance.
F	STRIKING	MEDIUM	Ensure tooling is secure in chuck. Wear safety glasses. Stand clear of moving parts on machine. Remove all loose objects around moving parts. Ensure correct spindle direction when milling.
H	ELECTRICAL	MEDIUM	All electrical enclosures should only be opened with a tool that is not to be kept with the machine. Machine should be installed & checked by a Licensed Electrician.
M	HIGH TEMPERATURE	LOW	Wear appropriate protective clothing to prevent hot swarf.
O	OTHER HAZARDS, NOISE.	LOW	Wear hearing protection as required.
Plant Safety Program to be read in conjunction with manufactures instructions			



www.machineryhouse.com.au



www.machineryhouse.co.nz

Authorised and signed by:
Safety officer: 
Manager: 

Revised Date: 12th March 2012

MACHINERYHOUSE



ENVIRONMENT PROTECTION

Recycle unwanted materials instead of disposing of them as waste. All tools, accessories and packaging should be sorted, taken to a recycling centre and disposed of in a manner which is compatible with the environment. When the product becomes completely unserviceable and requires disposal, drain any fluids (if applicable) into approved containers and dispose of the product and fluids according to local regulations.

Imported by

HARE & FORBES
MACHINERYHOUSE

Australian Distributor

Hare & Forbes
Machineryhouse
Sydney - Melbourne
Adelaide - Brisbane - Perth

Ph: 1300 202 200
www.machineryhouse.com.au

MACHINERYHOUSE

New Zealand Distributor

Machineryhouse
Auckland
Christchurch

Ph: 0800 142 326
www.machineryhouse.co.nz